



VALUE IN WEIGHING

April 2026

US PRODUCT GUIDE



CONTACT INFORMATION

Brecknell USA

1000 Armstrong Drive
Fairmont, Minnesota 56031
Toll-Free: 800-637-0529
Telephone: 507-238-8702
Fax: 507-238-8271
Email: sales@brecknellscales.com
www.brecknellscales.com

Brecknell Canada

6429 Abrams Street
St. Laurent, Quebec
Canada H4S 1X9
Toll Free: 800-268-1662
Telephone: 416-213-9900
Fax: 416-213-9960
Email: sales@brecknellscales.ca
www.brecknellscales.ca



COMPANY HISTORY

Brecknell has grown over the last century to become a global leader in weighing solutions.

Charles W Brecknell and Co was founded in 1913 in Birmingham, England and was the first firm to manufacture visible weighers for the wholesale industry. The company continued to expand into the 1920s and was purchased by W & T Avery Limited in 1926.

The Salter brand has also played a part in Brecknell's history. Products were sold under the name Salter Brecknell for several years when Avery Scales and Weigh-Tronix merged to form Avery Weigh-Tronix in 2003.

Today, the Brecknell brand is part of Avery Weigh-Tronix, a world leading manufacturer of industrial scales, weighing equipment and measurement devices. With a long history dating back to the 1700s, Avery Weigh-Tronix is headquartered in Birmingham, England and has manufacturing facilities in the UK, USA, China and India.

Brecknell scales are designed and manufactured with focus on high-value, easy-to-use and accurate weighing solutions for the majority of industries worldwide, from industrial weighing equipment, to office and medical scales. Our global presence ensures the highest quality service and support to our customers.





PRODUCT INDEX

Balance

EPB	6
MBS Series	7

Counting/Coin Scales

B140	8
------	---

Crane Scales

CS Series	9
BCS Series	10

Electronic Bench Scales

Model 405-LCD	11
---------------	----

Postal/Shipping

PS7	12
PS10	13
311	14
PS25	15
GP100 / GP250 USB	16
PS150 / PS400 Slimline	17
LPS15 / LPS150 / LPS400	18
PS-USB	19
3900LP Base + SBI 110 Indicator	20

Floor Scales

PS500 + SBI 140 Indicator	21
DS1000-LCD + SBI 210 Indicator	22
DCSB Floor Scale	23
DCSB Floor Scale + SBI 240 Indicator	24
DCSB Floor Scale + SBI 521 Indicator	25

Indicators

SBI 140	26
SBI 210	27
SBI 240	28
SBI 521	29

Hanging Scales

ElectroSamson	30
---------------	----

Medical Scales

MS-15	31
MS-20	32
HS-200M	33
HS-300	34
MS140-300 + SBI 140 Indicator	35
CS-200M	36
MS1000-LCD	37

Veterinary

PS1000 / PS2000 + SBI 140 Indicator	38
PS3000-LCD + SBI 210 Indicator	39

Portion Control

6030	40
------	----

Check Weighing

Model C3236	41
-------------	----

Price Computing

PC3060	42
--------	----

Point of Sale (PoS)

67XXU Series	43-44
--------------	-------

Load Cells

Load Cells	45
------------	----



EDUCATION
HOSPITALS

INDUSTRIAL
LABORATORIES

EPB Series

Features

- **Accuracy**– Within $\pm 0.04\%$
- **Capacity**– 500 g x 0.01 g, 3000 g x 0.1 g
- **Construction**– ABS case with stainless steel weighing platter and plastic protector cover
- **Power**– Two AAA batteries (included)
- **Display**– $\frac{9}{16}$ " / 14 mm high seven segment LCD with white backlight
- **Operator Keys**– On/Off, Function Mode, Tare, Count



Specifications

Unit: lb, oz, g, kg, tl, ct, PCS

Functions: Weight mode, tare, counting, calibration

Annunciators: Overload and low battery indicator

Auto-off: Shuts off after 60 seconds to help enhance battery life

Calibration: Three point

Tare: 100% push button

Operating Temperature: 50° F - 86° F / 10° C - 30° C

Scale Dimension (L x W x H):

5.5" x 4" x 0.8" / 140 mm x 107 mm x 20 mm

Platter Dimension (L x W x H):

4" x 4" / 100 mm x 100 mm

Product Weight: 0.276 lb / 0.125 kg

Packaging Dimension (L x W x H):

6.2" x 5.1" x 1.2" (160 mm x 130 mm x 32 mm)

Certifications: CE, FCC compliance, Prop 65, RoHS 3, WEEE

Part Number	Capacity	Ship Weight
816965007097	500 g x 0.01 g	0.055 lb
816965007103	3000 g x 0.1 g	0.055 lb





EDUCATION
HOSPITALS

INDUSTRIAL
LABORATORIES

MBS Series

Features

- **Accuracy**– Within $\pm 0.004\%$
- **Dual Range Capacity**–
300 g x 0.005 g - 600 g x 0.01 g
600 g x 0.01 g - 1200 g x 0.02 g
3000 g x 0.05 g - 6000 g x 0.1 g
- **Construction**– Robust plastic housing, stainless steel top plate
- **Power**– 12V 500mA power supply (included) or AA batteries (not included) with auto-off
- **Display** – Large, clear 6½ digits, 0.75" / 19 mm high seven segment LCD with blue backlight
- **Operator Keys**– On/Off, Count, Calibration, Tare, Print, Units (g, oz, ozt, dwt, lb, ct, %, pc)



Balances

Specifications

Unit: lb, oz, g, ozt, dwt, ct, % pc

COMM Port: Bi-directional RS232 (cable not included, p/n 52765-0949)

Battery Life: Approximately 15 hours

Operating Temperature: 50° F - 95° F / 10° C - 35° C

Scale Dimension (L x W x H):
MBS600:
9.5" x 6.5" x 2.3" / 241 mm x 165 mm x 58 mm

MBS1200 / MBS6000:
9.8" x 6.5" x 2.3" / 248 mm x 165 mm x 58 mm

Platter Dimension (L x W):
MBS600 (Diameter x H):
4.65" x 0.4" / 120 mm x 9.5 mm

MBS1200 / MBS6000 (L x W x H):
6.9" x 6.9" x 0.3"
175 mm x 175 mm x 8 mm

Packaging Dimension (L x W x H):
MBS600:
9.5" x 6.5" x 2.3" / 241 mm x 165 mm x 58 mm

MBS1200 / MBS6000:
9.8" x 6.5" x 2.3" / 248 mm x 165 mm x 58 mm

Packaging Contents: MBS600 includes a 200 g test weight and draft shield; MBS1200 includes a 500 g test weight

Certifications: Full FCC compliance, CE, UKCA, RoHS, WEEE

Part Number	Dual Range Capacity	Ship Weight
816965004898	300 - 600 g	4 lb
816965004904	600 - 1200 g	5 lb
816965004928	3000 - 6000 g	5 lb





**COIN COUNTING
FOOD SERVICE**

**LIGHT INDUSTRIAL
PARTS COUNTING**

B140

Features



- **Accuracy**– Within 0.01% of full load
- **Dual Range Capacity**–
6-15 lb x 0.0002-0.0005 lb
15-30 lb x 0.0005-0.001 lb
30-60 lb x 0.001-0.002 lb
3-6 kg x 0.0001-0.0002 kg
6-15 kg x 0.0002-0.0005 kg
15-30 kg x 0.0005-0.001 kg
- **Construction**– Rugged ABS base, stainless steel weight platter
- **Power**– AC adapter with rechargeable battery with 20 hours battery life between charges
- **Display**– Three six digit 0.56" / 14.2 mm high seven segment red LED with three brightness levels
- ***Currency Feature Added (60 lb / 30 kg only)**– US Dollars, GB Pounds and Euros with big and small bag selection



Specifications

Unit*/Currency: Units used to switch displayed weights between kg and lb. Currency used to switch between currency type (available in 60 lb/30 kg capacity only)

Minimum Piece Weight:

- 6 kg (0.05 g) 12 lb (0.0001 lb)
- 15 kg (0.1 g) 30 lb (0.0002 lb)
- 30 kg (0.2 g) 60 lb (0.0005 lb)

Power: Internal rechargeable battery giving 20 hours of use between charges. Recharge time approximately eight hours with 12V 500mA UK/EU/US power adapter (included).

Auto Off: Selectable between one and 30 minutes or off

Operator Keys: On/Off, Clear, Enter, Zero, Tare, Total, lb/kg, Piece Weight, PLU, Print, *Currency, Upper Limit, Lower Limit and 0 – 9 for data entry

Annunciators: Zero, tare, AC mains connected, battery charging, stable, big bag, small bag, kg and lb

Keyboard Functionality: 0-9– Used for keyboard entry of piece weight, sample size, and upper and lower limit settings

Zero: Return displayed weight and count to zero for accurate weighing and counting. Zero range capability is 5% of scale capacity.

Enter/Pcwt: Enter used to confirm or save entered data from keyboard. Pcwt used for keyboard entry of a known average piece weight

Tare: Used to zero off (up to 100% of capacity) an empty container or weight, not required in the calculation of an

average piece weight. Use of tare will reduce the scales maximum weight capacity by value stored

Total: Ability to add the display to an accumulator (Memory +) and only accumulate when there is a percentage of weight change

Clear/Hi/Lo: Clear to erase a keyed in value from the display if an error has been made. Hi/Lo is to set the upper and lower limits.

Upper: Used to set an upper limit quantity for count check

Lower: Used to set lower limit quantity for count check

Print: Output to RS232 communications (configurable)

***Mode:** Toggle between counting functions

Operating Temperature: 14° F to 104° F / -10° C to 40° C

Scale Dimension (L x W x H):

11.5" x 13.1" x 4.3" / 292 mm x 333 mm x 109 mm

Platter Dimension (L x W x H):

11.5" x 13" x 0.5" / 222 mm x 292 mm x 13 mm

Product Weight: 6.5 lb / 2.9 kg

Packaging Dimension (L x W x H):

16" x 14" x 8" / 406 mm x 356 mm x 203 mm

Certifications: NSF, UKCA, CE, full FCC compliance, Prop 65, CEC, ETL approved power adapter



Part Number	Dual Range Capacity	Ship Weight
816965005758	6 - 15 lb / 3 - 6 kg	12 lb
816965005765	15 - 30 lb / 6 - 15 kg	12 lb
816965005772	*30 - 60 lb / 15 - 30 kg	12 lb

*60 lb / 30 kg capacity counting/coin scale



GENERAL PURPOSE INDUSTRIAL **WAREHOUSE**

CS Series

Features

- **Accuracy**– Within $\pm 0.3\%$
- **Capacity**–
1000 lb x 0.5 lb / 500 kg x 0.2 kg
2000 lb x 1 lb / 1000 kg x 0.5 kg
- **Construction**– Aluminum die-cast case, alloy steel load cell, hook and shackle (safety load 150%)
- **Power**– Rechargeable battery or AC adapter (included). Remote control operates on two AA batteries (included).
- **Display**– 1.2" / 30 mm ultra-bright LED with adjustable brightness
- **Operator Keys**–
Scale: On/Off, Tare, Zero
Remote Control: Zero, tare, Hold, Clear, F1,F2, Off, M+ (Accumulator)



Specifications

- Unit:** lb, kg
- Accumulator Function:** Calculates total weight
- Elongated Upper Shackle:** Accommodates thick hooks
- Swivel Hook with Latch:** Makes load connection easy and secure
- Factory Calibration:** 39° latitude optimized
- Ultimate Safety Factor:** 400% F.S.
- Safety Load:** 150% F.S. of capacity

- Remote Functions:** Distance controls for zero, tare, hold, accumulator and power
- Typical Battery Life:** 20 hours between charges
- Operating Temperature:** 14° F to 104° F / -10° C to 40° C
- Scale Dimension (L x W x H):**
5.3" x 8.5" x 17" / 135 mm x 215 mm x 430 mm
- Packaging Dimension (L x W x H):**
12" x 11" x 7.5" / 305 mm x 280 mm x 190 mm

Part Number	Capacity	Ship Weight
816965001804	1000 lb x 0.5 lb / 500 kg x 0.2 kg	13.5 lb
816965001811	2000 lb x 1 lb / 1000 kg x 0.5 kg	13.5 lb



Crane Scales



**GENERAL PURPOSE
INDUSTRIAL**

WAREHOUSE

BCS Series

Features

EC Machinery Directive



- **Accuracy**– ± 0.15% at full load
- **Dual Range Capacity**–
2,000-6,000 lb x 1-2 lb
6,000-10,000 lb x 2-5 lb
1000-3000 kg x 0.5-1 kg
3000-5000 kg x 1-2 kg
- **Construction**– Aluminum-casting case, elongated upper hook, and a rotating shackle with a safety catch (EC approved)
- **Power**– Internal rechargeable battery or AC adapter
- **Display**– 1.4" / 35 mm ultra-bright LED with three adjustable brightness levels
- **Operator Keys**– On/Off, Zero, Tare, Hold, Total. Remote control included.

DR™
DUAL RANGE
TECHNOLOGY



Specifications

Unit: lb, kg

Factory Calibration: 39° latitude optimized

Typical Battery Life: Depending on LED brightness and idle mode setting, battery works from 60 hrs to 200 hrs

Charging Time: Approximately 12 hours; red charging, green finished

Remote Functions: Zero, tare, hold, total

Remote Distance: Minimum 32' / 10 m

Tare Range: 100% F.S.

Zero Range: 4% F.S.

Stable Time: ≤10 sec

Overload Indication: 100% F.S. +9 divisions

Ultimate Safety Factor: 400% F.S.

Safety Working Load (SWL):

BCS3000: 7,937 lb / 3600 kg

BCS5000: 13,228 lb / 6000 kg

Safety Load: Structurally tested to 150% SWL

Shackle and Hook Safety Ratio: 1:4 F.S. of capacity

Operating Temperature: 14° F to 104° F / -10° C to 40° C

Scale Dimension (L x W x H):

10" x 8" x 17" / 255 mm x 210 mm x 440 mm

Packaging Dimension (L x W x H):

23" x 10" x 12" / 600 mm x 270 mm x 310 mm

Certifications: UKCA, CE, RoHS 3, WEEE, UL approved power supply, Prop 65, FCC Compliant, EC Machinery Directive

Part Number	Dual Range Capacity	Ship Weight
816965006625	2000 - 6000 lb / 1000 - 3000 kg	28 lb
816965006632	6000 - 10,000 lb / 3000 - 5000 kg	28 lb





FOOD SERVICE PORTION CONTROL
LIGHT INDUSTRIAL

**UPDATED MODEL
COMING SOON**

Model 405-LCD

Features



- **Accuracy**– Within 0.04% at full load
- **Dual Range Capacity**–
6-15 lb x 0.001-0.002 lb
15-30 lb x 0.002-0.005 lb
3-6 kg x 0.0005-0.001 kg
6-15 kg x 0.001-0.002 kg
- **Construction**– ABS plastic housing with food safe 304 stainless steel weight platter
- **Power**– 9V 600mA power supply (included) or four AA batteries (not included)
- **Display**– 5½ digits seven segments 0.65" / 16.5 mm high digit LCD backlit
- **Operator Keys**– Tare/Unit, On/Off/Zero



Specifications

Unit: lb, oz, lb/oz, kg, g

Keyboard: Intuitive two-button operation Tare/Unit, On/Off/Zero

Standard Features: Integrated level-bubble, adjustable feet, selectable auto-off and 100% subtractive tare

Battery Life: 38 hours

Operating Temperature: 41° F to 95° F / 5° C to 35° C

Scale Dimension (L x W x H):

12" x 10" x 4.25" / 305 mm x 255 mm x 110 mm

Platter Dimension (L x W):

8.5" x 9.5" / 215 mm x 245 mm

Packaging Dimension (L x W x H):

15" x 12" x 7" / 385 mm x 305 mm x 180 mm

Certifications: UKCA, CE, CEC, FCC compliant, Prop 65, RoHS 3, ETL power adapter, WEEE, NSF pending

Part Number	Dual Range Capacity	Ship Weight
810036380218	6 - 15 lb / 3 - 6 kg	10 lb
810036380201	15 - 30 lb / 6 - 15 kg	10 lb





**EDUCATION
MAIL ROOM**

GENERAL PURPOSE

PS7

Features

- **Accuracy**– Within $\pm 0.1\%$
- **Capacity**– 7 lb x 0.002 lb / 7 lb x 0.01 oz / 3.2 kg x 1 g
- **Construction**– ABS plastic
- **Power**– Two AAA batteries (included)
- **Display**– Seven segment LCD
- **Operator Keys**– On/Off/Tare, Unit



Specifications

Unit: lb, lb/oz, g

Max Capacity: 7.22 lb / 7 lb 15 oz / 3299 g

Overload Indication: Err is displayed

Auto Shut Off: 30 seconds after no activity

Low Battery Indication

Automatic Zero Tare

Operating Temperature: 50° F to 104° F / 10° C to 40° C

Storage Temperature: -14° F to 140° F / -10°C to 60° C

Scale Dimension (L x W x H):

6.5" x 5.5" x 5.76" / 165 mm x 140 mm x 146 mm

Platter Dimension (L x W):

5.5" x 5.2" / 140 mm x 133 mm

Display Dimension (L x W):

3.4" x 1.4" / 86 mm x 36 mm

Product Weight: 2.25 lb / 1 kg

Packaging Dimension (L x W x H):

8" x 6" x 7.5" / 200 mm x 170 mm x 167 mm

Certifications: CE, FCC compliant, Prop 65, RoHS 3, WEEE

Part Number	Capacity	Ship Weight
816965005222	7 lb x 0.01 lb / 3.2 kg x 10 g	4 lb





EDUCATION MAIL ROOM GENERAL PURPOSE

COMING SOON

PS10

Features

- **Accuracy**– Within ±0.1%
- **Capacity**– 11 lb x 0.1 oz / 5 kg x 1 g
- **Construction**– ABS plastic
- **Power**– Three AAA batteries or USB-C cable (both included)
- **Display**– High definition, 1" / 25 mm digits high with LED display with touchless buttons
- **Operator Keys**– Weighing, Clock Mode, Tare, Aut-off



Specifications

Unit: lb, lb/oz, g
Max Capacity: 11.13 lb / 11 lb 21 oz / 5049 g
Overload Indication: Error "EEE"
Auto Shut Off & Low Battery Indication
Clock Function: Selectable 24-hour or 12-hour (AM/PM) format with automatic hourly display from HH:58 to HH:02 each hour, or manual display mode
Operating Temperature: 50° F to 104° F / 10° C to 40° C

Scale Dimension (L x W x H):
6.5" x 5.5" x 5" / 165 mm x 140 mm x 127 mm
Platter Dimension (L x W):
5.5" x 5.2" / 140 mm x 133 mm
Display Dimension (L x W):
3.4" x 1.4" / 86 mm x 36 mm
Product Weight: 2.25 lb / 1 kg
Packaging Dimension (L x W x H):
8" x 6" x 7.5" / 200 mm x 170 mm x 167 mm
Certifications: CE, FCC compliant, Prop 65, RoHS 3, WEEE

Part Number	Capacity	Ship Weight
810036380782	11 lb x 0.1 oz / 5000 g x 1 g	4 lb



Postal / Shipping



GENERAL PURPOSE **MAIL ROOM**
PORTION CONTROL

311

Features



- **Accuracy**– Within $\pm 0.06\%$
- **Capacity**– 11 lb x 0.1 oz / 5000 g x 1 g
- **Construction**– ABS plastic injection molded case and platter
- **Power**– Four AA batteries (included)
- **Display**– 0.6" / 15 mm high digits LCD
- **Operator Keys**– On/Tare, Off, Unit



Specifications

Unit: lb/oz, kg, g

Operating Temperature: 50° F to 104° F / 10° C to 40° C

Scale Dimension (L x W x H):
9.5" x 6.75" x 1.5" / 241 mm x 171 mm x 38 mm

Platter Dimension:
5.875" / 149 mm diameter

Product Weight: 1.05 lb / 0.47 kg

Packaging Dimension (L x W x H):
10.75" x 8" x 2.25" / 274 mm x 204 mm x 58 mm

Certifications: UKCA, CE, RoHS 3, WEEE, FCC, Prop 65, NSF

Part Number	Capacity	Ship Weight
816965001316	11 lb x 0.1 oz / 5000 g x 1 g	2 lb





GENERAL PURPOSE **MAIL ROOM**

PS25

Features

- **Accuracy**– Within ±0.1%
- **Capacity**– 25 lb x 0.2 oz / 11.5 kg x 0.02 kg
- **Construction**– ABS case with flip up roll and flat holder
- **Power**– Four AAA batteries or USB cable (both included)
- **Display**– 0.6" / 15 mm digits with backlight
- **Operator Keys**– On/Off/Tare, Unit



Specifications

Unit: lb/oz, kg, g

Dual Resolution:
 0 - 2 lb x 0.1 oz / 2 - 25 lb x 0.2 oz
 0 - 1 kg x 0.01 kg / 1 - 11.5 kg x 0.02 kg
 0 - 1000 g x 5 g / 1000 - 12000 g x 10 g

Operating Humidity Range: 20% to 90%

Auto Shut Off: 120 seconds after no activity

Overload: 120% of capacity

Low Battery Indication

Automatic Zero Tare

Operating Temperature: 50° F to 104° F / 10° C to 40° C

Storage Temperature: -14° F to 140° F / -10°C to 60° C

Scale Dimension (L x W x H):
 8.5" x 5.9" x 2" / 216 mm x 150 mm x 52 mm

Platter Dimension (L x W):
 8" x 5.9" / 203 mm x 150 mm

Product Weight: 2 lb / 0.9 kg

Packaging Dimension (L x W x H):
 10.75" x 8" x 4" / 273 mm x 203 mm x 101 mm

Certifications: FCC, Prop 65

Part Number	Capacity	Ship Weight
816965005239	25 lb x 0.2 oz / 11.5 kg x 0.02 kg	2.25 lb





**LIGHT INDUSTRIAL
MAIL ROOM**

WAREHOUSE

GP100 USB / GP250 USB

Features

- **Accuracy**– Within $\pm 0.6\%$
- **Capacity**–
100 lb x 0.2 lb / 45 kg x 0.1 kg
250 lb x 0.5 lb / 110 kg x 0.2 kg
- **Construction**– 22 gauge steel with ribbed base
- **Power**– One 9V battery (included), AC adapter or USB cable (not included)
- **Display**– Four large 1" / 25 mm H digits, backlit LCD
- **Operator Keys**– Zero, Tare, Unit



Specifications

Unit: lb, kg

Communication: USB virtual COM port (cable not included)

Discrete Switch Keyboard Technology: Unique key button design to ensure reliability and longevity

Electro-Mechanical Design: Ensures greater accuracy even at higher weigh capacities

Keyboard Functions:

HOLD: Freezes weight on the display only when a weight of 3 lbs or more is placed on the scale

TARE: Removes weight of empty container or item placed on the scale to obtain a net weight

UNITS: Scrolls between kilograms and pounds. Turns scale on or off and returns scale to zero weight.

Indicator Displayed Messages:

L0: Battery is weak. After five minutes scale will turn off.

Auto Zero Tracking: Includes AZT (Auto Zero Tracking) at 0.5 or manual push button to re-establish zero reference when displayed weight is less than 2% of capacity

Overload Capacity: Capable of withstanding 200 kg or 400 lb of weight without damaging the scale

Auto Shutdown: To conserve battery life the display will shutdown after two minutes of non-use. Can be configured via the keypad for Off, two or four minutes.

Operating Temperature: 42° F to 104° F / 5° C to 40° C

Scale Dimension (L x W x H):

10.95" x 12.50" x 2.20" / 278 mm x 318 mm x 56 mm

Product Weight: 6 lb / 3 kg

Packaging Dimension (L x W x H):

13.35" x 13.5" x 3" / 339 mm x 318 mm x 76 mm

Certifications: UKCA, CE, RoHS 3, WEEE, FCC

Part Number	Capacity	Ship Weight
816965006755	100 lb x 0.2 lb / 45 kg x 0.1 kg	8 lb
816965006731	250 lb x 0.5 lb / 110 kg x 0.2 kg	8 lb





GENERAL PURPOSE MAIL ROOM **SHIPPING**

PS150 and PS400 Slimline Features

- **Accuracy**– Within $\pm 0.25\%$
- **Capacity**–
150 lb x 0.1 lb / 70 kg x 0.05 kg
400 lb x 0.2 lb / 180 kg x 0.1 kg
- **Construction**– Low profile, portable, aluminum diecast base with ribbed and powder coated top plate. ABS desktop and wall mount indicator casing.
- **Power**– 9V 1A power supply with USA/UK adapters (included) or four AA batteries (not included)
- **Display**– Easy-to read 1.2" / 30 mm high LCD
- **Operator Keys**– Tare, On/Off, Unit



Specifications

Unit: lb, lb/oz, kg

Base Construction: Low profile, hard-wearing die cast base with ribbed top surface and a powder coated finish (110% overload protection)

Indicator: Easy-to-read 1.2" / 30 mm high digits, backlit LCD display in a compact, lightweight, and rugged ABS housing with 2 - 10 feet / 60 cm - 3 m coiled cable. Desktop and wall mount.

Features: General weighing in lb, lb/oz, or kg with autpower off if not used for five minutes

Battery Life: Up to 168 hours

Platform Dimension (L x W):
12" x 12" x 1" / 300 mm x 300 mm x 25 mm

Product Weight: 3.5 lb / 1.5 kg

Packaging Dimension (L x W x H):
19.3" x 13.1" x 1.97" / 490 mm x 332 mm x 49 mm

Certifications: FCC compliant, Prop 65, UL/CUL power adapter, UKCA, CE, RoHS 3, WEEE

Part Number	Capacity	Ship Weight
816965007516	150 lb x 0.1 lb / 70 kg x 0.05 kg	4.2 lb
816965007530	400 lb x 0.2 lb / 180 kg x 0.1 kg	4.2 lb





**LIGHT INDUSTRIAL
FOOD SERVICE**

**SHIPPING
WAREHOUSE**

LPS15 / LPS150 / LPS400

Features

- **Accuracy**– Within $\pm 0.1\%$
- **Dual Range Capacity**–
15-30 lb x 0.1-0.2 oz
60-150 lb x 0.5-1 oz
200-400 lb x 2-5 oz
6-15 kg x 0.002-0.005 kg
30-60 kg x 0.01-0.02 kg
100-182 kg x 0.05-0.1 kg
- **Construction**– Low profile stainless steel platform with mild steel understructure, stainless steel/ABS indicator with wall bracket and desk mount (included)
- **Power**–
LPS15/LPS150: Four AAA batteries (not included) or 9 VDC, 600mA adapter
LPS400: Four AAA batteries (included)
- **Display**– Five digit 0.65" / 17 mm digits with seven segment LCD
- **Operator Keys**– On/Off/Zero, Tare, Unit, Hold/Print

DR™
**DUAL RANGE
TECHNOLOGY**

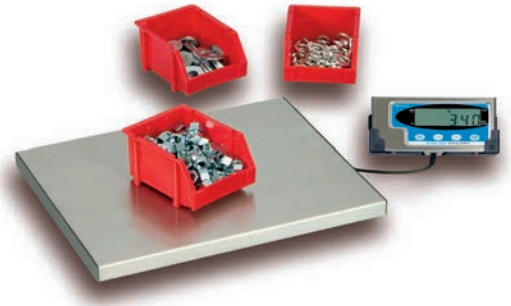

Specifications

Unit: lb, lb/oz, kg

COMM Port: RS232, bi-directional, full duplex (cable not included)

Battery Life: 20 hours

Operating Temperature: 41° F to 95° F / 5° C to 35° C

Platform Dimension (L x W x H):
15" x 12" x 1" / 380 mm x 305 mm x 27 mm

Indicator Dimension (L x W x H):
6.5" x 3.2" x 1.2" / 164 mm x 81 mm x 29 mm

Product Weight: 9 lb / 4 kg

Packaging Dimension (L x W x H):
17" x 15" x 2.3" / 450 mm x 400 mm x 60 mm

Certifications: FCC compliant, Prop 65, ETL power adapter, CE, RoHS 3, WEEE

Part Number	Dual Range Capacity	Ship Weight
816965004799	15 - 30 lb / 6 - 15 kg	11 lb
816965001224	60 - 150 lb / 30 - 60 kg	11 lb
816965006182	200 - 400 lb / 100 - 182 kg	11 lb





GENERAL PURPOSE MAIL ROOM **MANIFEST SYS. SHIPPING/RECEIVING**

PS-USB
Features



- **Accuracy**– NTEP and MC approved for 3000d (3500d for the 70 lb), Class III
- **Capacity**–
30 lb x 0.01 lb / 15 kg x 0.005 kg
70 x 0.02 lb / 30 kg x 0.01 kg
150 lb x 0.05 lb / 60 kg x 0.02 kg
- **Construction**– Durable cast aluminum upper load cell support-er and cast aluminum base with

- removable stainless steel platter
- **Power**– 9 VDC 600mA adapter with center positive (included) or four AA batteries (not included) or USB (VCP) cable (included)
- **Display**– 6½ digits 1" / 25 mm high, seven segments LCD with blue backlight
- **Operator Keys**– Hold/Setup, Print/Func, Acc/Total, Unit/Data, Tare/Preset, On/Off/Zero



Specifications

Unit: lb, lb/oz* (*non-NTEP), kg

Emulation Protocols: Standard NCI default with field configurable settings of NCI, 8213, 3835 and Autosend. Interfaces with software programs such as UPS™ Worldship Online.

RS232/USB (VCP): Bi-directional full duplex (USB and RS232 cables included)

Other Functions: Weighing, counting, check weighing, percent weighing, accumulation

Battery Life: 20 hours

Operating Temperature: 14° F to 104° F / -10° C to 40° C

Scale Dimension (L x W x H):

16" x 14" x 3.15" / 411 mm x 355 mm x 80 mm

Platform Dimension (L x W):

14" x 12" / 355 mm x 305 mm

Product Weight: 10 lb / 5 kg

Packaging Dimension (L x W x H):

20" x 18" x 6" / 505 mm x 465 mm x 150 mm

Certifications: NTEP CC# 15-084 / Measurement Canada AM-6006 (SBI-240), NTEP CC# 15-083 / Measurement Canada AM-5998 (PS-USB base), Base NSF listed

Part Number	Capacity	Ship Weight
816965006540	30 lb x 0.01 lb / 15 kg x 0.005 kg	14 lb
816965006533	70 lb x 0.02 lb / 30 kg x 0.01 kg	14 lb
816965006526	150 lb x 0.05 lb / 60 kg x 0.02 kg	14 lb





**FOOD SERVICE
LIGHT INDUSTRIAL**

**SHIPPING
WAREHOUSE**

3900LP Base with SBI 110 LCD Indicator

Features



- **Accuracy**– NTEP approved for 5000 divisions, Class III
- **Capacity**–
100 lb x 0.02 lb / 45 kg x 0.01 kg
250 lb x 0.05 lb / 113 kg x 0.02 kg
600 lb x 0.2 lb / 272 kg x 0.1 kg
- **Construction**– Carbon steel fabricated frame with food grade 304 stainless steel top pan and NTEP approved, ABS housed indicator
- **Power**– 12V 1A power adapter (included) with built-in rechargeable battery
- **Display**– Large 2" x 6.5" / 50 mm x 165 mm easy-to-read backlit display with 1.6" / 40 mm high digits
- **Operator Keys**– Units, Select, Print, Zero, Tare



Specifications

Unit: lb, kg

General Weighing: Designed to weigh in lb, kg or pieces, the 3900LP can easily be set into sample mode - ideal for counting a wide range of medium sized components.

Check Weighing & Check Counting: Ideal for guaranteeing product or box quantities are within an agreed weight or count size and for repetitive packing applications

Base Construction: 150% overload protection, this powder coated base frames is constructed using carbon steel tubular fabricated frame with four corner stops for extra load cell protection. The base frame is fitted with four large lockable adjustable anti-slip feet ideal for leveling the base if positioned on uneven ground.

Load Cell: This NTEP approved base is fitted with a robust approved aluminum IP65 (NEMA 4) load cell and a pole mounted ABS NTEP approved indicator

Top Pan: The base is fully covered with a removable hard-wearing, food grade 304 stainless steel top pan

Operating Temperature: 14° F to 104° F / -10° C to 40° C

Pole Dimension: 25.5" / 650 mm high

Platform Dimension (L x W x H):

Capacity	Dimension (in)	Dimension (cm)
100 lb / 45 kg	15.7 x 15.7 x 5.3	40 x 40 x 12
250 lb / 113 kg	15.7 x 19.7 x 5.7	40 x 50 x 15
600 lb / 272 kg	19.7 x 23.6 x 5.7	50 x 60 x 15

Packaging Dimension (L x W x H):

Capacity	Dimension (in)	Dimension (cm)
100 lb / 45 kg	31.3 x 20.7 x 6.5	76.5 x 52.5 x 16.5
250 lb / 113 kg	35.2 x 20.7 x 6.5	89.5 x 52.5 x 16.5
600 lb / 272 kg	38.7 x 24.6 x 7.2	98.5 x 62.5 x 18.5

Certifications: Indicator 5000d NTEP CC #18-125, base 5000d NTEP CC #18-124, FCC, CEC, Prop 65, UL power adapter

Part Number	Capacity	Ship Weight
816965007332	100 lb x 0.02 lb / 45 kg x 0.01 kg	29 lb
816965007349	250 lb x 0.05 lb / 113 kg x 0.02 kg	32 lb
816965007356	600 lb x 0.2 lb / 272 kg x 0.1 kg	58 lb
816965007363	SBI 110 Indicator (NTEP)	5 lb

Accessories / Options

Part Number	Description	Ship Weight
AWT15-501905	RS232 board	1 lb





LIGHT INDUSTRIAL **SHIPPING**
LIVESTOCK **WAREHOUSE**

PS500

Features

- **Accuracy**– Within ±0.2% of full capacity
- **Dual Range Capacity**–
250 lb x 0.1 lb - 500 lb x 0.2 lb
250 lb x 2 oz - 500 lb x 5 oz
100 kg x 0.05 kg - 250 kg x 0.1 kg
- **Construction**– Low profile stainless steel platform with mild steel understructure and stainless steel/ABS indicator and a rubber slip mat
- **Power**– Four AAA batteries (not included) or 9 VDC, 600mA adapter (included)
- **Display**– Five digit 0.65" / 17 mm digits with seven segment LCD
- **Operator Keys**– On/Off/Zero, Tare, Unit, Hold/Print

DR™
DUAL RANGE TECHNOLOGY



Shown with optional floor stand

Floor Scales

Specifications

Unit: lb, lb/oz, kg

Functions: Weight hold, stable weight indicators with auto power off

Overload Capacity: Capable of withstanding 150% capacity of weight without damaging scale

COMM Port: RS232, bi-directional, full duplex (cable not included)

Calibration: Front panel accessible

Battery Life: Approximately 20 hours continuous

Operating Temperature: 41° F to 95° F / 5° C to 35° C

Indicator Dimension (L x W x H):
6.5" x 1.2" x 3.2" / 165 mm x 30 mm x 81 mm

Indicator Packaging Dimension (L x W x H):
9.25" x 7.25" x 3" / 235 mm x 184 mm x 76 mm

Platform Dimension (L x W x H):
22" x 22" x 2" / 559 mm x 559 mm x 51 mm
*36" x 22" x 2" / 906 mm x 559 mm x 51 mm
42" x 22" x 2" / 1067 mm x 559 mm x 51 mm

Packaging Dimension (L x W x H):
22" x 22": 26" x 24" x 4" / 660 mm x 609 mm x 101 mm
36" x 22": 39" x 24" x 4" / 965 mm x 609 mm x 101 mm
42" x 22": 44" x 24" x 4" / 1117 mm x 609 mm x 101 mm

Options (not included) (L x W x H):
Indicator Floor Stand:
13.8" x 13.8" x 1" / 350 mm x 350 mm x 25 mm
Overall Height: 37" / 940 mm
Weight: 10 lb / 4.5 kg

Certifications: FCC compliance, ETL power adapter,

*Note: With rubber mat

Part Number	Platform Size	Dual Range Capacity	Ship Weight
816965001903	22" / 559 mm	250 - 500 lb / 100 - 250 kg	35 lb
816965001897	*36" / 906 mm	250 - 500 lb / 100 - 250 kg	37 lb
816965001453	42" / 1067 mm	250 - 500 lb / 100 - 250 kg	63 lb

*Note: With rubber mat

Accessories / Options

Part Number	Description	Ship Weight
810036380355	Indicator floor stand	12 lb
52751-2388	Rubber mat - 42"	5 lb



Shown with rubber mat



**LIGHT INDUSTRIAL
LIVESTOCK**

**SHIPPING
WAREHOUSE**

DS1000-LCD with SBI 210 LCD Indicator

Features

- **Accuracy**– Within $\pm 0.1\%$ at full load
- **Capacity**– 1000 lb x 0.2 lb / 500 kg x 0.1 kg
- **Construction**– Powder coated rugged smooth steel deck structure and built-in ramps, fitted with two handles and wheels for relocating the scale. Robust ABS plastic indicator with bench or pole brackets for mounting.
- **Power**– 9V 600mA universal power supply with USA/UK/EU adapters (included) or six AA batteries (not included)
- **Display**– Six large, easy-to read 1.5" / 38 mm high digits, large seven segment LCD with white backlight
- **Operator Keys**– On/Off/Zero, Tare, Unit, Print, Hold, Accumulate/Total



**Now with higher precision
and waterproof sensors**

Indicator Specifications

- Unit:** lb, kg, pcs, %
- Tare:** 100% subtractive. Ideal when filling a set recipe.
- Check Weighing:** Used when packing or filling to a set weight
- Counting:** Used for stock control or items within a box
- Accumulation:** Used to get the final consignment weight total
- Hold:** Captures and holds a stable weight on screen
- Percentage:** Used to carry out weightments on % basis
- Communication:** One USB (VCP) and one RS232 bi-directional full duplex port. Optional COM cables
- Print Format:** Configurable
- Indicator Mounting:** Desk or pole mountable, either vertically or horizontally
- Operating Temperature:** -14° F to 104° F / -10° C to 40° C
- Indicator Dimension (L x W x H):**
9.5" x 4.9" x 2.5" / 241 mm x 125 mm x 64 mm
- Packaging Dimension (L x W x H):**
5" x 9" x 4.5" / 385 mm x 230 mm x 122 mm

Part Number	Capacity	Ship Weight
810036380270	1000 lb x 0.2 lb / 500 kg x 0.1 kg	106.7 lb

Accessories / Options

Part Number	Description	Ship Weight
810036380355	Indicator floor stand	11 lb
AWT05-504386	Guard rail kit	11 lb

Floor Specifications

Load Cell: Four waterproof shear beam load cells connect to the IP65 junction box with 10 ft / 3 m interface cable

Product Dimension:

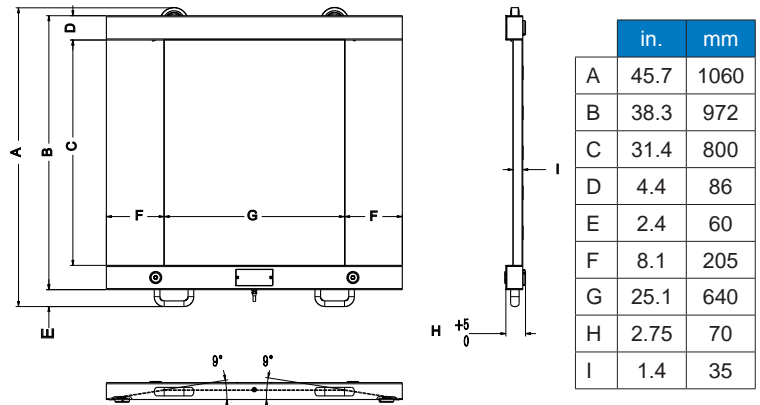

Portable: Fitted with two handles and wheels to easily relocate

Ramp: Designed with built-in 9 degree gradual angle to make entry and exit safe and easy

Product Weight: 103.4 lb / 47 kg

Packaging Dimension (L x W x H):
47.6" x 47.2" x 8.0" / 1210 mm x 1200 mm x 205 mm

Packaging Contents: DS1000-LCD platform, indicator, power supply with USA/US/EU plugs and indicator desk and pole mounting brackets

Certifications: FCC compliant, Prop 65, ETL power adapter, UKCA, CE, RoHS 3, WEEE



**LIGHT INDUSTRIAL
LIVESTOCK**

**SHIPPING
WAREHOUSE**

DCSB Series (deck only)

Features



- **Accuracy**– NTEP at 5000d, Class III
- **Capacity**–
5000 lb x 1 lb / 2500 kg x 0.5 kg
10,000 lb x 2 lb / 5000 kg x 1 kg
- **Construction**– Carbon steel fabrication with 1/4" / 6 mm thick safety tread top plate & heavy duty welded channel under structure, 150% overload protection
- **Versatile**– Pit mounted or free standing
- **Low Profile**– 3.1" / 91 cm high; 1.75" / 44 mm adjustable leveling feet
- **Warranty**– Includes a three year parts on DCSB deck from time of purchase. Consult factory.

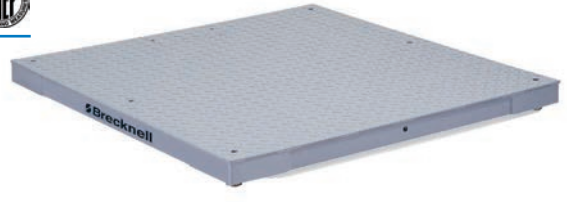

Floor Scales

Specifications

J-Box: IP65 ABS junction box with floor scale top access for easy installation and service

Leveling Feet: Four adjustable leveling feet with top hole access for a quick adjustment

Threaded Eye Bolts: Two threaded top access eye-bolt holes for easy mobility and pit service

Corner Protection: Closed corners to prevent damage to leveling feet

Load Cell: NTEP approved, waterproof IP67 potted 350 ohm +/-3.5Ω alloy steel load cells

Load Cell Rated Output: 3 mV/V

Overload Protection: 150% of rated capacity

Certifications: NTEP CC #02-070

Part Number	Model	Platform Size (L x W)	Capacity	Ship Weight
56977-0019	DCSB4848-05	48" x 48" / 1220 x 1220 mm	5000 lb x 1 lb / 2500 kg x 0.5 kg	290 lb
810036380027	DCSB5959-05	59" x 59" / 1500 x 1500 mm	5000 lb x 1 lb / 2500 kg x 0.5 kg	420 lb
56977-0209	DCSB4848-10	48" x 48" / 1220 x 1220 mm	10,000 lb x 2 lb / 5000 kg x 1 kg	286 lb
810036380034	DCSB5959-10	59" x 59" / 1500 x 1500 mm	10,000 lb x 2 lb / 5000 kg x 1 kg	448 lb

Note: Multiple packs of five+ are available upon request.

Accessories / Options

Part Number	Description / Capacity	Ship Weight
810036380355	SBI 240 indicator floor stand	11 lb
52775-0020	Ramp end with brackets, 48" W x 36" L / 1220 (W) x 915 mm (L)	220 lb
52775-0038	Ramp end with brackets, 60" W x 36" L / 1524 (W) x 915 mm (L)	301 lb
28209-0026	Floor mounting plates, 2500-5000 lb, set of four	11 lb
28213-0020	Floor mounting plates, 10,000 lb, set of four	11 lb



**LIGHT INDUSTRIAL
LIVESTOCK**

**SHIPPING
WAREHOUSE**

DCSB Floor Scale with SBI 240 LCD Indicator

Features



- **Accuracy**– NTEP 5000d, Class III
- **Capacity**–
2500 lb x 0.5 lb / 1250 kg x 0.2 kg
5000 lb x 1 lb / 2500 kg x 0.5 kg
10,000 lb x 2 lb / 5000 kg x 1 kg
- **Construction**– Mild steel with powder coat paint finish. 0.25" / 6 mm thick top plate and heavy duty welded channel support. Die cast aluminum indicator with adjustable steel stand.
- **Power**– 9V 600mA power supply with USA/UK/EU adapters (included) and four AA batteries (not included)
- **Display**– 6½ digits 1" / 25 mm high, large seven segment LCD with white backlight
- **Operator Keys**– Setup, Print/Func, Acc/Total, Unit/ Data, Tare/ Preset, Zero/On/Off
- **Warranty**– Includes three year parts on DCSB deck from time of purchase. Consult factory.



Indicator Specifications

Unit: lb, oz, lb/oz, kg, g, pcs, %

Functions: Weighing, check weighing and accumulation

Annunciators: -0-, motion, gross, net, tare, total, lo-ok-hi, lb, kg, print

Power: 9V 600mA, 110-230V switch mode external power supply with USA/UK/EU interchangeable plug adapters

Battery: Four AA batteries (not included)

Excitation Voltage: 5 VDC up to 55mA

Communication: One USB (VCP) and one RS232 bi-directional full duplex port. Optional COM cables.

Calibration: Front panel, multi-point

Floor Scale Connection: 9.8" / 250 mm cable is fixed to indicator side with quick release connector. An additional 14.76' / 4.5 m of cable is connected to the floor scale junction box.

Accessories: See DCSB Series (deck only) and SBI 240 Indicator page

Floor Specifications

J-Box: Weatherproof IP65 ABS housing with top access for ease of installation and service

Leveling Feet: Four top access holes for a quick installation

Threaded Eye Bolts: Four threaded top access eye-bolt holes for easy mobility and pit service

Corner Protection: Closed corners to prevent damage to leveling feet while installing the scale

Load Cell: Four waterproof IP67, NTEP approved, 350 Ohm ± 3.5 load cells

Load Cell Rated Output: 3 mV/V

Overload Protection: 150% of rated capacity

Certifications: NTEP CC #15-084, Class III, Measurement Canada AM-6006 (indicator) and CC #02-070 (base), Prop 65, ETL power adapter, UKCA, CE, RoHS 3, WEEE

Part Number	Model	Platform Size (L x W)	Capacity	Ship Weight
810036380041	DCSB3636-02	36" x 36" / 915 x 915 mm	2500 lb x 0.5 lb / 1250 kg x 0.2 kg	170 lb
810036380058	DCSB4848-05	48" x 48" / 1220 x 1220 mm	5000 lb x 1 lb / 2500 kg x 0.5 kg	320 lb
810036380072	DCSB5959-05	59" x 59" / 1500 x 1500 mm	5000 lb x 1 lb / 2500 kg x 0.5 kg	495 lb
810036380065	DCSB4848-10	48" x 48" / 1220 x 1220 mm	10,000 lb x 2 lb / 5000 kg x 1 kg	315 lb
810036380089	DCSB5959-10	59" x 59" / 1500 x 1500 mm	10,000 lb x 2 lb / 5000 kg x 1 kg	475 lb

Note: Multiple packs of five+ are available upon request.



**LIGHT INDUSTRIAL
LIVESTOCK**

**SHIPPING
WAREHOUSE**

DCSB Floor Scale with SBI 521 LED Indicator

Features



- **Accuracy**– NTEP 5000d, Class III
- **Capacity**–
5000 lb x 1 lb / 2500 kg x 0.5 kg
10,000 lb x 2 lb / 5000 kg x 1 kg
- **Construction**– Carbon steel fabrication with 1/4" / 6 mm thick safety tread top plate & heavy duty welded channel under structure, 150% overload protection
- **Power**– 6 volt 4 AH rechargeable internal lead acid battery with 110/220 AC internal transformer
- **Display**– 0.7"/ 17 mm LED
- **Operator Keys**– Hold/Setup, Print/Func, N/G/Total, Unit/Data, Tare/Preset, Zero/On/Off
- **Warranty**– Includes three year parts on DCSB deck from time of purchase. Consult factory.

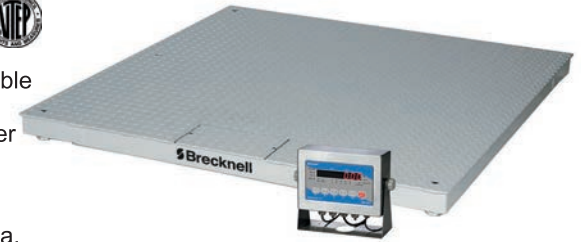

Indicator Specifications

Unit: lb, kg

Power: 6V 4 AH rechargeable internal lead acid battery with 110/220 AC internal transformer

Serial Port 1: Full-duplex RS232

Serial Port 2: Full-duplex RS232 or half-duplex RS485

Digital Calibration: Front panel calibration and configuration

Functions: Motion, zero, net, gross, tare, total, lb, kg, %, pcs, oz, peak/hold, hi, ok, lo, ac/chg

Display: Up to 50,000 graduations

Certifications: NTEP at 5,000d, Class III, CC #11-119

Accessories: See DCSB Series (deck only) and SBI 521 Indicator page

Floor Specifications

J-Box: IP65 ABS housing with top access for ease of installation and service

Leveling Feet: Four top access holes for a quick installation

Threaded Eye Bolts: Two threaded top access eye-bolt holes for easy mobility and pit service

Corner Protection: Closed corners to prevent damage to leveling feet while installing the scale

Interface Cable Length: 15' / 4.5 m with tinned leads (included)

Load Cell: NTEP approved, IP67 potted 350 ohm +/- 3.5Ω

Overload Protection: 150% of rated capacity

Part Number	Model	Platform Size (L x W)	Capacity	Ship Weight
816965005352	DCSB4848-05	48" x 48" / 1219 x 1219 mm	5000 lb x 1 lb / 2500 kg x 0.5 kg	320 lb
810036380096	DCSB5959-05	59" x 59" / 1500 x 1500 mm	5000 lb x 1 lb / 2500 kg x 0.5 kg	495 lb
816965005376	DCSB4848-10	48" x 48" / 1219 x 1219 mm	10,000 lb x 2 lb / 5000 kg x 1 kg	315 lb
810036380102	DCSB5959-10	59" x 59" / 1500 x 1500 mm	10,000 lb x 2 lb / 5000 kg x 1 kg	475 lb

Note: Multiple packs of five+ are available upon request.



**LIGHT INDUSTRIAL
VETERINARY**

**SHIPPING
WAREHOUSE**

SBI 140

Features

- **Resolution**– Displayed up to 1:10,000; internal 1:520,000
- **Construction**– Stainless steel/ABS case, complete with wall bracket and desk mount
- **Power**– Four AAA batteries or 9 VDC, 600mA adapter (both included)
- **Display**– Five digit 0.65" / 17 mm digits with seven segment LCD
- **Operator Keys**– On/Off/Zero, Tare, Unit, Hold/Print



Specifications

Unit: lb, lb/oz, kg

Protocol: Standard NCI interfaces to most common shipping software including, UPS™ Worldship Online and FedEx®. Not legal for trade.

Capabilities: Drives up to four load cells; compatible with all Brecknell platforms and any system with up to four 350 Ohm load cells 4.4 VDC, up to 55mA

Connection: 7.7" / 200 mm cable fixed to indicator with connector. Additional 16.4' / 5 m pigtail cable with connector that attaches to the indicator connector.

RS232: Supplied complete with 10' / 3 m cable (nine pin to nine pin type connector, bi-directional full duplex)

Annunciators: Zero, net, hold, kg/lb

Calibration: Front panel accessible

Battery Life: Battery life approximately 20 hours continuous

Operating Temperature: 41° F to 95° F / 5° C to 35° C

Scale Dimension (L x W x H):

6.5" x 1.2" x 3.2"
165 mm x 30 mm x 81 mm

Options (not included) (L x W x H):

Floor Stand:
13.8" x 13.8" x 1" / 350 mm x 350 mm x 25 mm
Overall Height: 37" / 940 mm
Weight: 10 lb / 4.5 kg

Packaging Dimension (L x W x H):

9.25" x 7.25" x 3" / 235 mm x 184 mm x 76 mm

Certifications: Full FCC compliance, ETL power adapter, CE, UKCA, WEEE

Part Number	Description	Ship Weight
52751-0556	SBI 140 LCD Indicator	3 lb

Accessories / Options

Part Number	Capacity	Ship Weight
810036380355	Indicator floor stand	11 lb

LIGHT INDUSTRIAL WAREHOUSE
VETERINARY/MEDICAL

SBI 210

Features

- **Resolution**– 100 -100,000d primary; 25 - 125,000d secondary. Unapproved.
- **Construction**– Rugged ABS enclosure housing with both desk and pole mounting brackets
- **Power**– 9V 600mA universal power supply with USA/UK/EU adapters (included) or six AA batteries (not included)
- **Display**– Six large, easy-to-read 1.5" / 38 mm high digits, large seven segment LCD with white backlight
- **Operator Keys**– On/Off/Zero, Tare, Unit, Print, Hold, Accumulate/Total



Specifications

Scales Functionality: Designed to be easy and simple to use. Ideal for most general weighing, veterinary or medical applications.

Unit Switching: lb, kg, pcs, %

Tare: 100% subtractive. Ideal for portion control applications.

Check Weighing: Used when packing or filling to a set weight. This provides the operator a fast & simple visual to let them know the product is within the accepted weight window.

Counting: Used for stock control or to quickly work out the quantity of items within a box

Accumulation: Used to get the final consignment weight total

Hold: This SBI 210 indicator has three main hold functions: manual hold, automatic hold and animal averaging hold making it ideal for a wide range of weighing applications.

Percentage: Used to carry out weightments on % basis

BMI (MS1000-LCD): Calculates the Body Mass Index (BMI)

Indicator Mounting: Can be desk mounted or pole mounted either vertically or horizontally

Battery Life: 24 hours with backlight, 37 hours without

Communication: One USB (VCP) and One RS232 bi-directional full duplex port (optional COM cables)

Calibration: Front panel accessible

Load Cell Capability: Can run up to four 350 Ohm load cells

Indicator Connection: 9.8" / 250 mm cable is fixed to indicator side with quick release connector. An additional 14.76' / 4.5 m of cable connects to the floor scale junction box (consult factory).

Annunciators: -0-, motion, gross, net, tare, hold, pcs, %, HI/OK/LOW, battery, accumulation

Operating Temperature: 14° F to 104° F / -10° C to 40° C

Dimensions (L x W x H):
9.5" x 4.9" x 2.5"
241 mm x 125 mm x 64 mm

Packaging Dimension (L x W x H):
5" x 9" x 4.5"
385 mm x 230 mm x 122 mm

Certifications: FCC compliant, Prop 65, ETL power adapter, UKCA, CE, RoHS 3, WEEE

Accessories / Options

Part Number	Description	Ship Weight
81003630287	SBI 210 LCD Indicator	4.4 lb

Note: MS1000-LCD Indicator, consult factory.

Part Number	Capacity	Ship Weight
810036380355	Indicator floor stand	11 lb
AWT05-100562	14.7' interface cable	5 lb
AWT05-100563	SBI 100 converter	0.4 lb
AWT05-507974	5.9' USB cable	0.5 lb
1140-13842	10' RS232 cable	0.5 lb



**LIGHT INDUSTRIAL
VETERINARY**

WAREHOUSE

SBI 240

Features

- **Accuracy**– NTEP and Canadian approved for 5000d, Class III
- **Resolution**– 100-100,000d primary units / 100-125,000d second unit
- **Construction**– Robust die cast aluminium indicator housing with adjustable steel desk/wall bracket
- **Power**– 9V 600mA, 110-230V switch mode external power supply and comes standard with USA/UK/EU interchangeable plug adapters or four AA batteries (not included)
- **Display**– 6½ digits 1" / 25 mm high, large seven segment LCD with white backlight
- **Operator Keys**– Setup, Print/Func, Acc/Total, Unit/ Data, Tare/ Preset, Zero/On/Off

Measurement
Canada Approval



Specifications

Unit: lb, oz, lb/oz, kg, g, pcs, %

Protocol: Standard NCI interfaces to most common shipping software including, USPS™ Worldship Online

Functions: Weighing, counting, check weighing, percentage weighing and accumulation

Load Cell Capability: Can run up to four 350 Ohm load cells

Excitation: 5 VDC up to 55mA

Internal ADC: 16,000,000

Indicator Connection: 9.8" / 250 mm cable is fixed to indicator side with quick release connector. An additional 14.76' / 4.5 m of cable connects to the floor scale junction box (included).

Communication: One USB (VCP) and One RS232 bi-directional full duplex port

Annunciators: -0-, motion, gross, net, tared, total, pcs, lb, kg, lo, ok, hi

Calibration: Front panel accessible

Battery Life (One Load Cell): 35 hours with backlight, 50 hours no backlight

Battery Life (Four Load Cells): 32 hours with backlight, 45 hours no backlight

Time and Date: Year/Month/Day

Operating Temperature: 14° F to 104° F / -10° C to 40° C

Dimensions (L x W): 9.5" x 4.9" x 2.5"
241 mm x 125 mm x 64 mm

Shipping Dimensions (L x W x H): 11" x 10" x 4"
280 mm x 250 mm x 100 mm

Certifications: CE, NTEP COC #15-084 (indicator), Measurement Canada AM-5998, RoHS 3, UKCA, ETL power adapter, WEEE

Part Number	Description	Ship Weight
816965006960	SBI 240 LCD Indicator	3 lb

Accessories / Options

Part Number	Capacity	Ship Weight
810036380355	Indicator floor stand	11 lb
AWT05-507974	5.9' USB cable	0.5 lb
1140-13842	10' RS232 cable	0.5 lb

LIGHT INDUSTRIAL SHIPPING

WAREHOUSE

SBI 521

Features



- **Accuracy**– NTEP 10,000 divisions, Class III
- **Resolution**– 100 -100,000d primary units; 100 - 125,000d secondary units
- **Construction**– Heavy duty stainless steel IP65 with stainless steel swivel stand
- **Power**– 6V 4 AH rechargeable internal lead acid battery with 110/220 AC internal transformer (included) or external customer supplied 12 VDC
- **Display**– Seven digit, seven segment, 0.7" / 17 mm LED
- **Operator Keys**– Hold/Set up, Print/Func, N-G/Total, Unit/Data, Tare/Preset, Zero/On-Off



LED

Specifications

Unit: lb, lb/oz, kg, PCS, %

Serial Point: Two full duplex RS232 serial port: demand or continuous

Max Display Range: -999,999 to 999,999

Function: Hold, counting, totalizing, check weighing, percentage, peak

Digital Calibration: Full front panel configuration

Multi-Point Calibration: Up to four points

Peak Capture Rate: 80Hz

Real Clock: Built-in nonvolatile real time and date

Analog Circuit: 24-bit A/D converter
Division Number Range: 100-100,000

Load Cell Excitation:
Voltage: 5 VDC, Max. Current: 120mA, can power 8 @ 350 Ohm load cells
Max Sensitivity: -3 mV/V to +3 mV/V

Communication:

Serial Port1: Full-duplex RS232
Serial Port2: Full-duplex RS232 or half-duplex RS485
Baud Rate: Selectable: 1200-2400-4800-9600-19200-38400-57600 bps
Data Output Format: 8N1, 7O1, 7E1
Protocol: Programmable
Print Format: Selectable Gross Weight, Tare, Net, Time/Date, Scale ID, Percent, Count, Piece Weight, Total

Approximate Battery Life: LCD: 48 hrs*; LED: 30 hrs*
**Battery life will vary depending on number and type of load cells used, duration of backlight, temperature, and other factors*

Operating Temperature: 14° F to 104° F / -10° C to 40° C

Indicator Dimension (L x W x H):
3.5" x 10.5" x 8.5" / 89 mm x 267 mm x 216 mm

Packaging Dimension (L x W x H):
11" x 11" x 6.5" / 279 mm x 279 mm x 165 mm

Certifications: NTEP CC# 11-119, Measurement Canada AM-5923, FCC, Prop65, UL listed adapter

Part Number	Description	Ship Weight
AWT05-506155	SBI 521 LED	10 lb

Accessories / Options

Part Number	Description	Ship Weight
AWT05-100825	Indicator interface cable (15' / 4.5 m)	5 lb



ANGLING
FOOD SERVICE

HEALTH CARE
INDUSTRIAL

ElectroSamson

Features

- **Accuracy**– Within $\pm 0.1\%$
- **Capacity**–
22 lb x 0.02 lb/¼ oz / 10 kg x 0.01 kg
55 lb x 0.05 lb/½ oz / 25 kg x 0.02 kg
99 lb x 0.1 lb/1 oz / 45 kg x 0.05 kg
- **Construction**– Tough ABS case
- **Power**– 9V alkaline battery (included)
- **Display**– Angled 0.6" / 15 mm seven segment LCD
- **Operator Keys**– On/Zero, Off, Hold, Unit



Specifications

Unit: lb, lb/oz, kg

Battery Life: Over eight hours continuous

Functions: 100% tare, hold, selectable units from lb, lb/oz or kg, auto-off after two minutes to help prolong battery life when not in use

Annunciators: Tare, hold

Operating Temperature: 0° C to +40° C / 32° to 104° F

Scale Dimension (Hook to Hook) (L x W x H):
13" x 3.75" x 2.25" / 330 mm x 95 mm x 76 mm

Product Weight: 0.85 lb / 0.38 kg

Packaging Dimension (L x W x H):
11" x 5.5" x 3" / 279 mm x 140 mm x 76 mm

Packaging Contents: Fixed hook, robust double hand metal lift bar and padded carrying pouch with belt clip

Part Number	Capacity	Ship Weight
816965007479	22 lb x 0.02 lb/¼ oz / 10 kg x 0.01 kg	1.5 lb
816965007486	55 lb x 0.05 lb/½ oz / 25 kg x 0.02 kg	1.5 lb
816965007493	99 lb x 0.1 lb/2 oz / 45 kg x 0.05 kg	1.5 lb



Sling



Padded carrying pouch with belt clip included



HEALTH CARE VETERINARY



MS-15

Features

- **Accuracy**– Within $\pm 0.2\%$
- **Capacity**– 44 lb x 0.01 lb / 20 kg x 5 g
- **Construction**– ABS plastic with removable weighing tray
- **Power**– Four AA batteries (included)
- **Display**– 1" / 25 mm LCD with four active digits
- **Operator Keys**: On/Tare, Mode, Memory



Specifications

Unit: lb, kg

Weighing Range: 0.5 lb to 44 lb / 0.2 kg to 20 kg

Operating Temperature: 41° F to 95° F / 5° C to 35° C

Scale Dimension (L x W):
23" x 13" / 578 mm x 334 mm

Inside Tray Dimension (L x W):
23" x 11" / 584 mm x 292 mm

Product Weight: 6.6 lb / 3 kg

Packaging Dimension (L x W x H):
25" x 15" x 6" / 635 mm x 381 mm x 152 mm

Packaging Contents: Scale and manual

Certifications: FC, Prop 65, CE

Part Number	Capacity	Ship Weight
816965005123	44 lb x 0.01 lb / 20 kg x 5 g	9 lb





HEALTH CARE

VETERINARY



MS-20S

Features

- **Accuracy**– Within $\pm 0.1\%$
- **Capacity**– 44 lb x 0.5 oz / 20 kg x 10 g
- **Construction**– Stainless steel tray. Plastic housed indicator with 16"-26" coiled cable.
- **Power**– 9V 100mA AC adapter or 9V alkaline battery (not included)
- **Display**– 1" / 25 mm LCD with four active digits
- **Operator Keys**: On/Off/Tare, Unit, Hold



Specifications

Unit: lb, lb/oz, kg

Tray: Stainless steel

Operating Temperature: 5° C to 35° C / 41° F to 95° F

Tray Dimension (L x W x H):
21" x 10" x 2" / 533 mm x 254 mm x 51 mm

Inside Tray Dimension (L x W x H):
MS20S: 20½" x 11½" x 2¼" / 521 mm x 292 mm x 57 mm

Packaging Dimension (L x W x H):
5 5/8" x 12 3/10" x 10 4/5"
143 mm x 313 mm x 275 mm

Product Weight: 8.2 lb / 3.7 kg

Certifications: Full FCC compliance; UL/CUL power adapter

Part Number	Model	Capacity	Ship Weight
816965001002	MS-20S	44 lb x 0.5 oz / 20 kg x 10 g	10.75 lb





HEALTH CARE
HEALTH CLUBS

SCHOOLS



HS-200M

Features

- **Capacity**– 440 lb x 4 oz / 200 kg x 100 g
- **Construction**– Steel with durable white finish
- **Height Gauge** to 7' / 210 cm
- **Rollers Included** for Easy Transport
- **Easy-to-Read Dual Beam**
- **Dual Marked** in Pounds / Kilograms
- **Accurate Full Range Weights**



Specifications

Scale Dimension (L x W x H):
22" x 10.8" x 58.5" / 559 mm x 275 mm x 1485 mm

Platform Dimension (L x W):
14.75" x 10.8" / 375 mm x 275 mm

Height Rod Range:
2' to 7' x 0.125" / 60 cm to 210 cm x 0.1 cm

Product Weight: 38 lb / 17 kg

Packaging Dimension (L x W x H):
59" x 20" x 6" / 1499 mm x 508 mm x 152 mm

Packaging Contents: Manual, platform, height scale, weighing tower, wheels and miscellaneous hardware

Part Number	Capacity	Ship Weight
816965004850	440 lb x 4 oz / 200 kg x 100 g	40 lb



HEALTH CARE

HEALTH CLUBS



HS-300

Features

- **Accuracy**– Within $\pm 0.1\%$
- **Capacity**– 660 lb x 0.2 lb / 300 kg x 0.1 g
- **Construction**– Mild steel with durable powder coated white finish
- **Power**– Four AAA batteries or 9 VDC, 600mA US power adapter (both included)
- **Display**– 0.625" / 17 mm high backlit LCD
- **Operator Keys**– Hold/Print, Unit, Tare, On/Off/Zero



Specifications

Unit: lb, lb/oz, kg

Serial Port: One full duplex RS232 with cable

Battery Life: Approximately 20 hours continuous

RS232: Supplied complete with 10' / 3 mm cable (nine pin to nine pin type connector, bi-directional full duplex)

Rollers Included for Easy Transport

Operating Temperature: 41° F to 95° F / 5° C to 35° C

Platform Dimension (L x W):
20.5" x 20.5" / 521 mm x 521 mm

Height Rod Dimension:
2' to 7' x 0.125" / 60 cm to 210 cm x 0.1 cm

Handrail Height (W x H):
16" x 49" / 406 mm x 1245 mm

Indicator Dimension (L x W x H):
6.5" x 1.2" x 3.2" / 165 mm x 30 mm x 81 mm

Packaging Dimension (L x W x H):
54.5" x 30.5" x 9" / 1384 mm x 775 mm x 230 mm

Packaging Contents: Platform, indicator, handrail, manual, height gauge, RS232 cable, power supply and miscellaneous hardware

Certifications: Full FCC compliance, ETL power adapter, Prop 65, CE, UKCA, WEEE, RoHS

Part Number	Capacity	Ship Weight
816965004812	660 lb x 0.2 lb / 300 kg x 0.1 kg	54 lb



HEALTH CARE HEALTH CLUBS



MS140-300 with SBI 140 LCD Indicator

Features

- **Accuracy**– Within $\pm 0.09\%$
- **Capacity**– 660 lb x 0.2 lb / 660 lb x 5 oz / 300 kg x 0.1 kg
- **Construction**– Stainless steel weighing surface with mild steel foam covered handrails. Rigid base design.
- **Power**– Four AAA batteries or 9 VDC, 600mA wall mount adapter (both included)
- **Display**– Five digit 0.65" / 17 mm digits with seven segment LCD
- **Operator Keys**– On/Off/Zero, Tare, Unit, Hold/Print



Specifications

Unit: lb, lb/oz, kg

Serial Port: One full duplex RS232 with cable

RS232: Supplied complete with 10' cable (nine pin to nine pin type connector, bi-directional full duplex)

Integrated Wheel Kit: For easy portability

Weight Hold: May be used to freeze and store the displayed weight so that you may attend to the patient's needs

Operating Temperature: 41° F to 95° F / 5° C to 35° C

Scale Dimension (L x W x H):
20.5" x 20.5" x 44.25" / 520 mm x 520 mm x 1135 mm

Platform Dimension (L x W x H):
20.5" x 20.5" x 2.5" / 520 mm x 520 mm x 65 mm

Indicator Dimension (L x W x H):
6.5" x 1.2 x 3.2" / 165 mm x 30 mm x 81 mm

Packaging Dimension (L x W x H):
46" x 25" x 6" / 1168 mm x 635 mm x 152 mm

Packaging Contents: Manual, platform, three piece handles, power supply, RS232 cable, indicator, three hex wrenches and pull through string

Certifications: FCC compliance, ETL power adapter

Part Number	Capacity	Ship Weight
816965004829	660 lb x 0.2 lb / 300 kg x 0.1 kg	55 lb



HEALTH CARE

HEALTH CLUBS



CS-200M

Features

- **Capacity**– 440 lb x 4 oz / 200 kg x 100 g
- **Construction**– Powder coated steel with die-cast beam



Specifications

Unit: lb, kg

Locking Rear Wheels for Safety

Swivel Front Wheels for Easy Transport

Lift Away Armrests for Easy Access

Accurate Full Range Weights

Scale Dimension (L x W x H):
25" x 35" x 40" / 635 mm x 889 mm x 1016 mm

Seat Dimension (L x W x H):
14" x 16" x 13" / 350 mm x 405 mm x 340 mm

Product Weight: 70 lb / 32 kg

Packaging Dimension (L x W x H):
30" x 24" x 25" / 762 mm x 609 mm x 635 mm

Packaging Contents: Manual, footrest, two armrests, scale with wheel assembly, seat, back handle, weighing tower and miscellaneous hardware

Part Number	Capacity	Ship Weight
816965004843	440 lb x 4 oz / 200 kg x 0.1 kg	80 lb



ASSISTED LIVING

HEALTH CARE

MS1000-LCD with SBI 210 LCD Indicator

Features

- **Accuracy**– Within $\pm 0.1\%$ at full load
- **Capacity**– 1000 lb x 0.2 lb / 500 kg x 0.1 kg
- **Construction**– Powder coated rugged smooth steel deck structure and built-in ramps, fitted with two handles and wheels for relocating the scale. Robust ABS plastic indicator with bench or pole brackets for mounting.
- **Power**– 9V 600mA power supply with US power adapter (included) or six AA batteries (not included)
- **Display**– Six large, easy-to-read 1.5" / 38 mm high digits, large seven segment LCD with white backlight
- **Operator Keys**– On/Off/Zero, Tare, Unit, Print, Hold, BMI



Indicator Specifications

Unit: lb, kg

Scale Functionality: This scale is designed to be easy and simple to use

Tare: 100% subtractive

BMI: Calculates the Body Mass Index (BMI)

Hold: Used to freeze a displayed weight value once the patient steps off the scale

Communication: One USB (VCP) and one RS232 bi-directional full duplex port. Optional COM cables

Print Format: Configurable

Indicator Mounting: Desk or pole mountable, either vertically or horizontally

Operating Temperature: 14° F to 104° F / -10° C to 40° C

Indicator Dimension (L x W x H):
9.5" x 4.9" x 2.5" / 241 mm x 125 mm x 64 mm

Packaging Dimension (L x W x H):
5" x 9" x 4.5" / 385 mm x 230 mm x 122 mm

Certifications: FCC compliant, Prop 65, ETL power adapter

Part Number	Capacity	Ship Weight
810036380263	1000 lb x 0.2 lb / 500 kg x 0.1 kg	110 lb

Accessories / Options

Part Number	Description	Ship Weight
810036380355	Indicator floor stand	11 lb

Floor Specifications

Load Cell: Four waterproof shear beam load cells connect to the IP65 junction box with 10 ft / 3 m interface cable

Product Dimension:

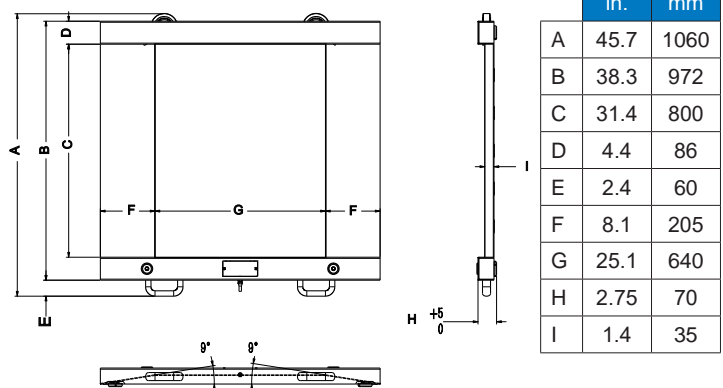

Portable: Fitted with two handles and wheels to easily relocate

Ramp: Designed with built-in 9 degree gradual angle to make entry and exit safe and easy

Guard Rail Dimension (L x W):
33.85" x 27.6" / 860 mm x 700 mm

Product Weight: 100 lb / 45 kg

Packaging Dimension (L x W x H):
48" x 47.2" x 8.1" / 1220 mm x 1200 mm x 205

Packaging Contents: MS1000-LCD platform, guard/handrail, indicator, power supply with US plug and indicator mounting brackets



**ANIMAL WEIGHING
INDUSTRIAL**

**SHIPPING
WAREHOUSE**

PS1000 / PS2000

Features

- **Accuracy**– Within $\pm 0.1\%$
- **Capacity**–
1000 lb x 0.5 lb / 500 kg x 0.2 kg
2000 lb x 1 lb / 1000 kg x 0.5 kg
- **Construction**– Rugged steel with tread plate surface and stainless steel/ABS indicator
- **Power**– 9 VDC, 600mA adapter (included) or four AAA batteries (not included)
- **Display**– Five digit 0.625" / 17 mm digits with seven segment LCD
- **Operator Keys**– On/Off/Zero, Tare, Unit, Hold/Print



PS1000

Shown with optional indicator stand

Indicator Specifications

Unit: lb, lb/oz, kg

Animal Weighing Software

Functions: Weight hold, stable weight indicators with auto power off

Overload Capacity: Capable of withstanding 150% capacity of weight without damaging scale

RS232: Supplied complete with 10' / 3 m cable (nine pin to nine pin type connector, bi-directional full duplex)

Calibration: Front panel accessible

Battery Life: Approximately 20 hours continuous

Operating Temperature: 41° F to 95° F / 5° C to 35° C

Indicator Dimension (L x W x H):
6.5" x 1.2" x 3.2" / 165 mm x 30 mm x 81 mm

Packaging Dimension (L x W x H):
9.25" x 7.25" x 3" / 235 mm x 184 mm x 76 mm

Certifications: RoHS, WEEE, Prop65 and FCC compliant, ETL, UKCA/CE

Floor Specifications

Adjustable Foot Pads: To work on uneven surfaces

Two Handles: Easily relocate

Ramped Ends

Platform Dimension (L x W x H):
PS1000: 55.75" x 20.25" x 2.5"
1416 mm x 514 mm x 64 mm

PS2000: 59" x 30" x 2.5"
1498 mm x 762 mm x 64 mm

Packaging Dimension (L x W x H):
PS1000: 57.5" x 22" x 4"
1461 mm x 559 mm x 102 mm

PS2000: 64" x 36" x 7"
1626 mm x 914 mm x 178 mm

Options (not included) (L x W x H):
Floor Stand:
13.8" x 13.8" x 1" / 350 mm x 350 mm x 25 mm
Overall Height: 37" / 940 mm
Weight: 10 lb / 4.5 kg

Part Number	Capacity	Ship Weight
816965001460	1000 lb x 0.5 lb / 500 kg x 0.2 kg	77 lb
816965003907	2000 lb x 1.0 lb / 1000 kg x 0.5 kg	124 lb

Accessories / Options

Part Number	Description	Ship Weight
810036380355	Indicator floor stand	11 lb
816965007073	PS1000 mat kit	13 lb
816965007080	PS2000 mat kit	16 lb



PS2000

Shown with optional indicator stand

**ANIMAL WEIGHING
INDUSTRIAL**

**SHIPPING
WAREHOUSE**

PS3000-LCD with SBI 210 Indicator

Features

- **Accuracy**– Within $\pm 0.1\%$ at full load
- **Capacity**– 3000 lb x 1 lb / 1500 kg x 0.5 kg
- **Construction**– Mild steel construction with safety tread plate surface and rubber mat. Robust ABS indicator housing.
- **Connection**– 250 mm / 9.8" cable fixed to indicator with connector, 3 m / 9.8' interface cable with connector
- **Power**– 9V 600mA universal power supply with USA/UK/EU adapters (included) or six AA batteries (not included)
- **Display**– Six large, easy-to-read 1.5" / 38 mm high digits, large seven segment LCD with white backlight
- **Operator Keys**– On/Off/Zero, Tare, Unit, Print, Hold, Accumulate/Total



Indicator Specifications

Unit: lb, kg, pcs, %

Tare: 100% subtractive

Check Weighing: Used when packing or filling to a set weight

Counting: Used for stock control or items within a box

Accumulation: Used to get the final consignment weight total

Hold: Captures and holds a stable weight on screen

Percentage: Used to carry out weightments on % basis

Communication: One USB (VCP) and one RS232 bi-directional full duplex port. Optional COM cables

Print Format: Configurable

Indicator Mounting: Desk or pole mountable, either vertically or horizontally

Operating Temperature: 41° F to 95° F / 5° C to 35° C

Indicator Dimension (L x W x H):
9.5" x 4.9" x 2.5" / 241 mm x 125 mm x 64 mm

Packaging Dimension (L x W x H):
5" x 9" x 4.5" / 385 mm x 230 mm x 122 mm

Certifications: FCC compliant, Prop 65, ETL power adapter, UKCA, CE, RoHS 3, WEEE

Floor Specifications

Load Cell: Four OIML CS waterproof IP67 shear beam load cells made from nickel-plated alloy steel

J-Box: Weatherproof IP65 ABS housing, fitted with a 10' / 3 m interface cable as standard

Anti-Slip Rubber Mat: Easy on animal hooves, reduce noise and risk of slipping (included)

150% Overload Protection

Platform Dimension (L x W x H):
78.75" x 39.37" x 3.93" / 2000 mm x 1000 mm x 100 mm

Platform Weight: 264 lb / 120 kg

Packaging Dimension (L x W x H):
81" x 42" x 7.1" / 2050 mm x 1050 mm x 180 mm

Packaging Contents: PS3000-LCD platform, indicator, power supply with USA/US/EU plug ends and indicator mounting brackets

Options (not included) (L x W x H):
Floor Stand:
13.8" x 13.8" x 1" / 350 mm x 350 mm x 25 mm
Overall Height: 37" / 940 mm
Weight: 10 lb / 4.5 kg

Part Number	Capacity	Ship Weight (platform + indicator)
810036380348	3000 lb x 1 lb / 1500 kg x 0.5 kg	275 + 4.4 lb

Accessories / Options

Part Number	Description	Ship Weight
810036380355	Indicator floor stand	11 lb

Note: See SBI 210 page for more accessories.





FOOD SERVICE

WEIGHT LOSS
CENTERS

6030

Features

IP67

DRTM
DUAL RANGE
TECHNOLOGY

- **Accuracy**– Within 0.06% of full load
- **Dual Range Capacity**–
5 lb x 0.001 lb - 10 lb x 0.002 lb
5 lb x 0.02 oz - 10 lb x 0.05 oz
80 x 0.02 oz - 160 oz x 0.05 oz
2500 g x 0.5 g - 5000 g x 1 g
- **Construction**– Food grade stainless steel upper cover and removable stainless steel platter for easy cleaning
- **Power**– 9 volt alkaline battery (included)
- **Display**– 0.8" / 20 mm LCD with five digits
- **Operator Keys**– On/Off, Tare/Zero, Unit



Specifications

Unit: lb, oz, lb/oz, g

Operating Temperature: 41° F - 95° F / 5° C - 35° C

Scale Dimension (L x W x H):

6.6" x 5.9" x 0.1" / 170 mm x 160 mm x 40 mm

Platter Dimension (L x W):

5.9" x 4.7" / 150 mm x 120 mm

Product Weight: 1.5 lb / 0.6 kg

Packaging Dimension (L x W x H):

10" x 7.75" x 3" / 254 mm x 196 mm x 76 mm

Certifications: UKCA, CE, RoHS 3, WEEE, FCC, Prop 65

Part Number	Dual Range Capacity	Ship Weight
816965006557	5 - 10 lb / 80 - 160 oz / 2500 - 500 g	2 lb





FOOD INDUSTRY PORTION CONTROL

UPDATED MODEL COMING SOON

Model C3236

Features

IP68

- **Accuracy**– Within $\pm 0.04\%$
- **Dual Range Capacity**–
6-15 lb x 0.01-0.02 oz
15-30 lb x 0.02-0.05 oz
3-7 kg x 0.2-0.5 g
7-15 kg x 0.5-1 g
- **Construction**– Food grade 304 stainless steel housing and top pan and IP68 (NEMA4X) water ingress protection
- **Power**– Removable AC power adapter (included) along with a built-in rechargeable lead acid battery
- **Display**– Large 1.2" x 3.5" / 30 mm x 90 mm red LED display with five 0.6" / 15 mm high digits
- **Operator Keys**– On/Zero/Tare, Function, Unit, Off



Specifications

Unit: lb, kg, g, lb-oz (not legal-for-trade)
Main Functionality: General weighing and check weighing with audio low, ok and high buzzer
Battery Life: Up to 62 hours
Operating Temperature: 14° F to 104° F / -10° C to 40° C
Scale Dimension (L x W x H):
 13" x 11.4" x 4.3" / 330 mm x 290 mm x 110 mm

Platter Dimension (L x W):
 7.5" x 10" / 190 mm x 255 mm
Product Weight: 10.5 lb / 4.5 kg
Packaging Dimension:
 14.4" x 13.2" x 5.7" / 365 mm x 335 mm x 145 mm
Certifications: FCC, Prop 65, UL, UKCA, CE, RoHS 3, WEEE

Part Number	Dual Range Capacity	Ship Weight
816965007172	6 - 15 lb / 3 - 7 kg	7.7 lb
816965007189	15 - 30 lb / 7 - 15 kg	7.7 lb



Check Weighing



**CANDY STORE
FARMERS MARKET**

GROCERY STORES

PC3060

Features



- **Accuracy**— NTEP approved for 3000 divisions, Class III
- **Capacity**— 30/60 lb x 0.01/0.02 lb / 15/30 kg / 0.005/0.01 kg
- **Construction**— Compact and robust ABS plastic housing with food grade 304 stainless steel weight platter
- **Power**— 120V 500mA power adapter (included) and a 6V/3.2 Ah lead acid rechargeable battery
- **Display**— Six large 2.5" x 0.8" / 65 mm x 20 mm high LCD display with blue backlit 1/2" / 12 mm high digits for displaying weight, unit price and total price
- **Operator Keys**— Eight function keys and 12 numeric entry keys: Change, Memory Add, PLU, Save, Quantity, Zero, Units, Tare



Specifications

Unit: lb, kg

Key Features: Ten pre-stored PLU's, auto price clear and up to 100 entry accumulator

Battery Life: 40 hours

Tare: 100%

Operating Temperature: 14° F to 104° F / -10° C to 40° C

Scale Dimension (L x W x H):
12.3" x 10.3" x 4.3" / 313 mm x 263 mm x 109 mm

Platter Dimension (L x W):
8" x 10.3" / 204 mm x 263 mm

Product Weight: 7.2 lb / 3.3 kg

Packaging Dimension (L x W x H):
14.4" x 13.2" x 7.5" / 365 mm x 335 mm x 190 mm

Certifications: 3000d NTEP CC #18-119, 3000d EC #0200-NAWI-05154

Part Number	Capacity	Ship Weight
816965007257	30/60 lb x 0.01/0.02 lb / 15/30 kg x 0.005/0.01 kg	8 lb



POINT OF SALE PORTION CONTROL

67XXU Series

Features

Measurement Canada Approval



- **Accuracy**– NTEP and MC approved for 3000 divisions, Class III
- **Capacity**– 5 lb / 2.5 kg, 15 lb / 7.5 kg, 30 lb / 15 kg, 60 lb / 30 kg
- **Construction**–
6702U/6710U: Aluminum plate understructure and stainless steel platter
6720U: Heavy duty cast aluminum X shape support and stainless steel platter
- **Power**– 9 VDC, 600mA power adapter with center positive (included) or USB (VCP) cable (not included)
- **Display**– ABS plastic housing. 5½ digits seven segments 0.58" / 15 mm high LCD with blue backlight
- **Operator Keys**– Hold/Print, On/Off/Zero, Unit, Tare

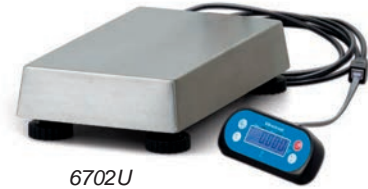

6702U

Specifications

Unit: lb, oz, lb/oz* (*non-NTEP), kg, g

NSF Approved: For use in food contact applications

Easy-to-Install: Bi-directional nine pin RS232 and USB port. Interfaces to most electronic cash registers and point of sale software

Interface Protocols: NCI, ECR, 8213 (Sharp), EH (PS60)

Quick Disconnect: Makes all cable connections easy

"Touchless" Tare: Just wave or place your hand over the display to zero the scale. Electronic mechanism enhances food handling safety.

Check Weighing: OK annunciator with alarm

Count Weighing: Piece counting

Hold: Positive peak, negative peak, average hold and auto hold

Auto Zero Tracking: Zero light indicator and manual control when out of range

Configurable Photo Eye

Zero Range: Selectable up to full scale

Alternate Calibration Points: Allows use of less than full capacity weight for calibration

Auto-Compensation: Local gravity effects to avoid initial calibration with test weights

Adjustable Filter Settings: Reduce environmental vibration noise for rapid setting and quick measurements

Communication: USB (VCP) and nine pin RS232

Remote Display Enclosure (L x W x H):

6702U/6710U:
2.4" x 5.8" x 1.1" / 62 mm x 148 mm x 29 mm

Adjustable Height:

6702U/6710U: 2.75" - 3.25" / 69 mm x 82 mm
6720U: 3.5" - 4" / 88 mm 101 mm

Certifications: NTEP 13-074*, Measurement Canada AM-5912C, CE/UKCA, ETL power adapter, NSF/ANSI standard 169

*Counting function non-trade approved



6710U

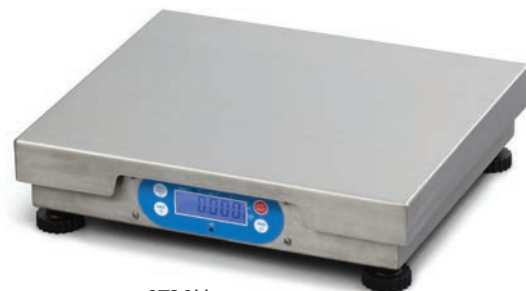

6720U

Continued on next page



Model	Part Number	Platter Size	Capacity	Volt	Ship Weight
6702U	816965006137	6" x 10" 152 mm x 254 mm	5 lb x 0.001 lb / 2.5 kg x 0.0005 kg (external display)	110V	8 lb
6702U	816965005857		15 lb x 0.005 lb / 7.5 kg x 0.002 kg (external display)	110V	8 lb
6702U	816965006083		30 lb x 0.01 lb / 15 kg x 0.005 kg (external display)	110V	8 lb
6710U	816965005864	10" x 10" 254 mm x 254 mm	15 lb x 0.005 lb / 7.5 kg x 0.002 kg (external display)	110V	12 lb
6710U	816965005871		30 lb x 0.01 lb / 15 kg x 0.005 kg (external display)	110V	12 lb
6720U	816965005888	12" x 14" 305 mm x 355 mm	15 lb x 0.005 lb / 7.5 kg x 0.002 kg (internal display)	110V	13.7 lb
6720U	816965005895		30 lb x 0.01 lb / 15 kg x 0.005 kg (internal display)	110V	13.7 lb
6720U	816965005901		30 lb x 0.01 lb / 15 kg x 0.005 kg (external display)	110V	13.7 lb
6720U	816965006144		60 lb x 0.02 lb / 30 kg x 0.01 kg (internal display)	110V	13.7 lb

Accessories / Options

Part Number	Description	Ship Weight
816965005918	6702U/6710U, 12" / 305 mm display post	1 lb
816965005925	6702U/6710U, display bracket attaches display to scale base	0.27 lb
1140-13842	10' / 3 m RS232C interface cable (9-pin M/F pass through) (67XXU)	0.4 lb
AWT05-507974	6' / 1.8 m USB A to A cable (67XXU)	0.1 lb
816965005949	Remote display with cable 24" / 610 mm (67XXU)	0.5 lb
816965005932	Remote display with extension cable 7' / 2 m (67XXU)	0.4 lb
816965005963	Remote display kit with 12" / 305 mm post and 7' / 2 m cable (67XXU)	1.6 lb
816965005956	7' / 2 m display extension cable (67XXU)	0.4 lb

Model	Scale Dimension (L x W x H)	Remote Display Dimension (L x W x H)
6702U	11.8" x 6.4" x 3.1" 300 mm x 164 mm x 80 mm	2.4" x 5.8" x 1.1" 61.8 mm x 148.1 mm x 29 mm
6710U	12.9" x 10.4" x 3.1" 330 mm x 266 mm x 80 mm	2.4" x 5.8" x 1.1" 61.8 mm x 148.1 mm x 29 mm
6720U	13.9" x 12.0" x 3.4" 355 mm x 305 mm x 88 mm	Optional

Model	Packaging Dimension (L x W x H)
6702U	14.5" x 15.5" x 5.5" 368 mm x 393 mm x 139 mm
6710U	15.5" x 18.5" x 5.5" 393 mm x 469 mm x 139 mm
6720U	18.3" x 19.8" x 5.7" 465 mm x 505 mm x 145 mm



VALUE IN WEIGHING

Load Cells

Load Cells

Brecknell's comprehensive range of load cells, transducers, weigh pads and hardware can be found in our online 2026 Load Cell catalog.





Brecknell USA

1000 Armstrong Drive
Fairmont, Minnesota 56031

Toll-Free: 800-637-0529
Telephone: 507-238-8702
Fax: 507-238-8271

Email: sales@brecknellscales.com
www.brecknellscales.com

Brecknell Canada

6429 Abrams Street
St Laurent, Quebec
Canada H4S 1X9

Toll-Free: 800-561-9461
Telephone: 514-695-0380
Fax: 514-695-0385

Email: sales@brecknellscales.ca
www.brecknellscales.ca